

# StarlettePlus-E Refrigeration Dryers

SPS 004 - 100



Untreated compressed air is wet. 100% saturated as it leaves the compressor aftercooler, water vapour in the compressed air cools as it enters the air receiver and distribution piping, resulting in the formation of condensed liquid water and water aerosols. Wet compressed air leads to corrosion, the growth of micro-organisms and the formation of oily, acidic compressor condensate.

For a manufacturing facility reliant on compressed air for automation, these contaminants can directly impact safety, productivity and efficiency.

Compressed air treatment is therefore essential and for non-critical uses of compressed air, the refrigeration dryer is an ideal choice.

## Refrigeration Dryers

Refrigeration dryers use a closed loop cooling system to lower the temperature of the compressed air to just above freezing, causing condensation of water vapour.

Most of the condensed liquid is then removed by an integral water separator and drained away. Prior to leaving the dryer, the compressed air is re-heated by the incoming compressed air to prevent condensation on the outside of the downstream distribution piping.

Refrigeration dryers should always be installed with general purpose and high efficiency coalescing filters and are an effective way to reduce water vapour, liquid water and water aerosols for general purpose compressed air applications.

Environmentally friendly Refrigeration Dryers, that work with Low GWP refrigerant in compliance with the requirements of the F-Gas Regulation (EU 517/2014), are the best choice to protect your investment, the climate and the environment.



## Advantages

- Parker StarlettePlus-E refrigeration dryers are developed around a state-of-the-art aluminium heat exchanger (E-Pack)
- The E-Pack heat exchanger has a large air/air heat exchanger to pre-cool the incoming compressed air and reduce energy consumption
- The highly efficient E-Pack design results in a refrigerant circuit with lower absorbed power and uses a smaller volume of refrigerant than other comparable dryers
- The E-Pack design utilises low pressure drop, cross flow heat exchangers to reduce operational costs
- The E-pack heat exchanger includes a high efficiency. Stainless steel demister separator for liquid removal
- In compliance with the F-Gas regulation, Low GWP environmentally friendly refrigerant R513A on all units. A protection for the environment and an insurance for the investment
- All models are equipped as standard with a digital controller that provides an indication of compressed air temperature, volt free alarm contact, service reminder and integral timed drain control
- StarlettePlus-E models are dual frequency (50Hz or 60Hz)
- Optional Energy Saving model versions (models SPS026 - SPS100) enables the dryer to save additional energy at partial load by cycling the refrigerant compressor while cooling the inlet air using the cold reserve stored in the E-Pack mass



ENGINEERING YOUR SUCCESS.

## Dryer Performance

Dryer Models	Dewpoint (Standard)		Dewpoint (Option 1)		Dewpoint (Option 2)	
	°C	°F	°C	°F	°C	°F
SPS	+3	+37	+7	+45	+10	+50

## Technical Data

Dryer Models	Min Operating Pressure		Max Operating Pressure		Min Operating Temperature		Max Operating Temperature		Max Ambient Temperature		Electrical Supply (Standard)	Electrical Supply (Optional)	Thread Connections	Noise Level
	bar g	psi g	bar g	psi g	°C	°F	°C	°F	°C	°F				
SPS 004-062	2	29	16	232	5	41	65	149	50	122	230V 1ph 50Hz / 60Hz	N/A	BSPP	<75
SPS 080-100			14	203										

## Flow Rates

Model	Pipe Size	Inlet Flow Rate 50 Hz					50Hz kW	Inlet Flow Rate 60Hz					60Hz kW
		L/s	m³/min	m³/hr	cfm	L/s		m³/min	m³/hr	cfm			
SPS 004	1/2"	7	0.4	24	14	0.13	8	0.47	28	16	0.16		
SPS 007	1/2"	12	0.7	42	25	0.14	13	0.78	47	28	0.17		
SPS 009	1/2"	15	0.9	54	32	0.15	17	1.00	60	35	0.19		
SPS 014	3/4"	23	1.4	84	49	0.15	27	1.60	96	57	0.18		
SPS 018	3/4"	30	1.8	108	64	0.16	34	2.07	124	73	0.20		
SPS 026	1"	43	2.6	156	92	0.29	49	2.93	176	104	0.36		
SPS 032	1"	53	3.2	192	113	0.30	61	3.63	218	128	0.37		
SPS 040	1"	67	4.0	240	141	0.31	76	4.53	272	160	0.38		
SPS 052	1 1/2"	87	5.2	312	184	0.46	100	6.02	361	212	0.56		
SPS 062	1 1/2"	103	6.2	372	219	0.57	119	7.15	429	253	0.69		
SPS 080	1 1/2"	133	8.0	480	282	0.73	154	9.25	555	327	0.90		
SPS 100	1 1/2"	167	10.0	600	353	0.74	191	11.48	689	406	0.91		

Stated flows are for operation at 7 bar (g) (102 psi g) with reference to 20°C, 1 bar (a), 0% relative water vapour pressure, 25 °C cooling air temperature, 35 °C air inlet temperature and +3°C pressure dewpoint. All models supplied with low GWP refrigerant R513A.

For flows at other conditions, apply the correction factors shown below.

## Product Selection & Correction Factors

For correct operation, compressed air dryers must be sized using for the maximum (summer) inlet temperature, maximum (summer) ambient temperature, minimum inlet pressure, required outlet dewpoint and maximum flow rate of the installation.

To select a dryer, first calculate the MDC (Minimum Drying Capacity) using the formula below then select a dryer from the flow rate table above with a flow rate equal to or above the MDC.

$$\text{Minimum Drying Capacity} = \text{System Flow} \times \text{CFIT} \times \text{CFAT} \times \text{CFMIP} \times \text{CFOD}$$

### CFIT - Correction Factor Maximum Inlet Temperature

Maximum Inlet Temperature	°C	25	30	35	40	45	50	55	60	65
	°F	77	86	95	104	113	122	131	140	149
Correction Factor	50Hz	0.83	0.83	1.00	1.30	1.61	2.00	2.33	2.38	2.50
	60Hz	0.85	0.85	1.00	1.32	1.61	2.04	2.56	2.63	2.78

### CFAT - Correction Factor Maximum Ambient Temperature

Maximum Ambient Temperature	°C	20	25	30	35	40	45	50
	°F	68	77	86	95	104	113	122
Correction Factor	50Hz	0.93	1.00	1.02	1.09	1.15	1.22	1.28
	60Hz	0.96	1.00	1.06	1.11	1.18	1.25	1.33

### CFMIP - Correction Factor Minimum Inlet Pressure

Minimum Inlet Pressure	bar g	3	4	5	6	7	8	9	10	11	12	13	14	15	16
	psi g	44	58	73	87	100	116	131	145	160	174	189	203	218	232
Correction Factor	50Hz	1.35	1.23	1.11	1.06	1.00	0.93	0.85	0.83	0.81	0.79	0.77	0.75	0.73	0.71
	60Hz	1.45	1.23	1.11	1.06	1.00	0.93	0.85	0.83	0.81	0.79	0.77	0.75	0.73	0.71

### CFOD - Correction Factor Outlet Dewpoint

Outlet Dewpoint	°C	+3	+5	+7
	°F	+37	+41	+45
Correction Factor	50Hz	1.00	0.78	0.70
	60Hz	1.00	0.79	0.72

## Controller Functions

Dryer Models	Controller Function							
	Power On Indication	Visual Fault Indication	Compressed Air Temperature	EST - Energy Saving Technology	Filter Service Indicator	Dryer Service Indicator	Fault Relay: Power Loss	4-20mA Dewpoint Re-transmission
SPS	•	•	•	On E-Saving Models		•	•	On E-Saving Models

## Recommended Filtration

Model	Pipe Size BSP or NPT	Dryer Inlet	Dryer Outlet
		General Purpose Pre-Filter	High Efficiency Post Filter
SPS 004	1/2"	AOPX010C	AAPX010C
SPS 007	1/2"	AOPX015C	AAPX015C
SPS 009	1/2"	AOPX015C	AAPX015C
SPS 014	3/4"	AOPX020D	AAPX020D
SPS 018	3/4"	AOPX020D	AAPX020D
SPS 026	1"	AOPX025E	AAPX025E
SPS 032	1"	AOPX025E	AAPX025E
SPS 040	1"	AOPX025E	AAPX025E
SPS 052	1 1/2"	AOPX030G	AAPX030G
SPS 062	1 1/2"	AOPX030G	AAPX030G
SPS 080	1 1/2"	AOPX035G	AAPX035G
SPS 100	1 1/2"	AOPX035G	AAPX035G

Filtration Performance	General Purpose Pre-filter	High Efficiency Post Filter
<b>Filtration Grade</b>	Grade AO	Grade AA
<b>Filtration Type</b>	Coalescing	Coalescing
<b>Particle Reduction (inc water &amp; oil aerosols)</b>	Down to 1 micron	Down to 0.01 micron
<b>Maximum Remaining Oil Aerosol Content at 21°C</b>	≤0.5 mg/m <sup>3</sup> (≤0.5 ppm(w))	≤0.01 mg/m <sup>3</sup> (≤0.01 ppm(w))
<b>Filtration Efficiency</b>	99.925%	99.9999%

## Weights & Dimensions

Model	Pipe Size BSP or NPT	Dimensions						Weight	
		Height (H)		Width (W)		Depth (D)		kg	lbs
		mm	ins	mm	ins	mm	ins		
SPS 004	1/2"	520	20.5	300	11.8	400	15.7	24	53
SPS 007	1/2"	520	20.5	300	11.8	400	15.7	24	53
SPS 009	1/2"	520	20.5	300	11.8	400	15.7	25	55
SPS 014	3/4"	580	22.8	330	13.0	550	21.7	35	77
SPS 018	3/4"	580	25.6	330	13.0	550	21.7	36	79
SPS 026	1"	650	25.6	400	15.7	630	24.8	46	101
SPS 032	1"	650	25.6	400	15.7	630	24.8	46	101
SPS 040	1"	650	25.6	400	15.7	630	24.8	47	104
SPS 052	1 1/2"	650	25.6	400	15.7	630	24.8	53	117
SPS 062	1 1/2"	650	25.6	400	15.7	630	24.8	55	121
SPS 080	1 1/2"	840	33.1	450	17.7	780	30.7	80	176
SPS 100	1 1/2"	840	33.1	450	17.7	780	30.7	80	176

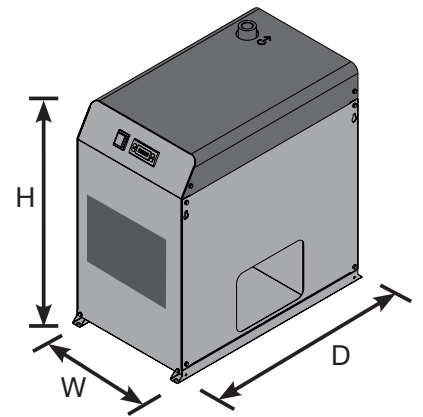

## Quality Assurance / IP Rating / Pressure Vessel Approvals

<b>Development / Manufacture</b>	ISO 9001 / ISO 14001
<b>Ingress Protection Rating</b>	IP22 Indoor Use Only
<b>EU</b>	Pressure vessel approved for fluid group 2 in accordance with the Pressure Equipment Directive 2014/68/EU
<b>USA</b>	Approval to ASME VIII Div. 1 not required
<b>AUS</b>	Approval to AS1210 not required
<b>For use with Compressed Air Only</b>	

# Parker Worldwide

## Europe, Middle East, Africa

### AE – United Arab Emirates,

Dubai

Tel: +971 4 8127100

### AT – Austria, St. Florian

Tel: +43 (0)7224 66201

### AZ – Azerbaijan, Baku

Tel: +994 50 2233 458

### BE/NL/LU – Benelux,

Hendrik Ido Ambacht

Tel: +31 (0)541 585 000

### BY – Belarus, Minsk

Tel: +48 (0)22 573 24 00

### CH – Switzerland, Etoy

Tel: +41 (0)21 821 87 00

### CZ – Czech Republic,

Prague

Tel: +420 284 083 111

### DE – Germany, Kaarst

Tel: +49 (0)2131 4016 0

### DK – Denmark, Ballerup

Tel: +45 43 56 04 00

### ES – Spain, Madrid

Tel: +34 902 330 001

### FI – Finland, Vantaa

Tel: +358 (0)20 753 2500

### FR – France, Contamine s/Arve

Tel: +33 (0)4 50 25 80 25

### GR – Greece

Tel: +30 69 44 52 78 25

### HU – Hungary, Budaörs

Tel: +36 23 885 470

### IE – Ireland, Dublin

Tel: +353 (0)1 466 6370

### IL – Israel

Tel: +39 02 45 19 21

### IT – Italy, Corsico (MI)

Tel: +39 02 45 19 21

### KZ – Kazakhstan, Almaty

Tel: +7 7273 561 000

### NO – Norway, Asker

Tel: +47 66 75 34 00

### PL – Poland, Warsaw

Tel: +48 (0)22 573 24 00

### PT – Portugal

Tel: +351 22 999 7360

### RO – Romania, Bucharest

Tel: +40 21 252 1382

### RU – Russia, Moscow

Tel: +7 495 645-2156

### SE – Sweden, Borås

Tel: +46 (0)8 59 79 50 00

### SL – Slovenia, Novo Mesto

Tel: +386 7 337 6650

### TR – Turkey, Istanbul

Tel: +90 216 4997081

### UK – United Kingdom, Warwick

Tel: +44 (0)1926 317 878

### ZA – South Africa, Kempton Park

Tel: +27 (0)11 961 0700

## North America

### CA – Canada, Milton, Ontario

Tel: +1 905 693 3000

### US – USA, Cleveland

Tel: +1 216 896 3000

## Asia Pacific

### AU – Australia, Castle Hill

Tel: +61 (0)2-9634 7777

### CN – China, Shanghai

Tel: +86 21 2899 5000

### HK – Hong Kong

Tel: +852 2428 8008

### IN – India, Mumbai

Tel: +91 22 6513 7081-85

### JP – Japan, Tokyo

Tel: +81 (0)3 6408 3901

### KR – South Korea, Seoul

Tel: +82 2 559 0400

### MY – Malaysia, Shah Alam

Tel: +60 3 7849 0800

### NZ – New Zealand, Mt Wellington

Tel: +64 9 574 1744

### SG – Singapore

Tel: +65 6887 6300

### TH – Thailand, Bangkok

Tel: +662 186 7000

### TW – Taiwan, Taipei

Tel: +886 2 2298 8987

## South America

### AR – Argentina, Buenos Aires

Tel: +54 3327 44 4129

### BR – Brazil, Sao Jose dos Campos

Tel: +55 080 0727 5374

### CL – Chile, Santiago

Tel: +56 22 303 9640

### MX – Mexico, Toluca

Tel: +52 72 2275 4200



### EMEA Product Information Centre

Free phone: 00 800 27 27 5374

(from AT, BE, CH, CZ, DE, DK, EE, ES, FI, FR, IE, IL, IS, IT, LU, MT, NL, NO, PL, PT, RU, SE, SK, UK, ZA)

### US Product Information Centre

Toll-free number: 1-800-27 27 537

[www.parker.com/gsf](http://www.parker.com/gsf)