



MXLE

Low energy heatless dryers



ENGINEERING YOUR SUCCESS.

Compressed air contamination is a real problem for industry

In today's modern production facilities, the use of compressed air is often pivotal to manufacturing processes. Irrespective of whether the compressed air comes into direct contact with the product or is used to automate a process, provide motive power, or even to generate other gases on-site, a clean, dry, reliable compressed air supply is essential to maintain efficient and cost effective production.

Parker provides complete compressed air treatment solutions to suit every industry, application & budget.

The benefits of using Parker compressed air treatment solutions:

- Plant Reliability - trouble free operation from equipment and processes using compressed air
- Clean Dry Air available for all applications
- No contamination of products / processes / equipment
- Low Maintenance Costs – Reduce or eliminate unexpected / unplanned plant maintenance for better budget control
- Lower plant energy consumption
- Lower plant environmental impact
- Legislation compliance – e.g. assist in complying with hygiene legislation in the Food, Beverage & Pharmaceutical industries



Compressed air dryers – The heart of the compressed air treatment solution

At the heart of any compressed air treatment solution is the dryer, it's purpose, to remove water vapour, stop condensation, corrosion and in the case of adsorption dryers, inhibit the growth of micro-organisms.

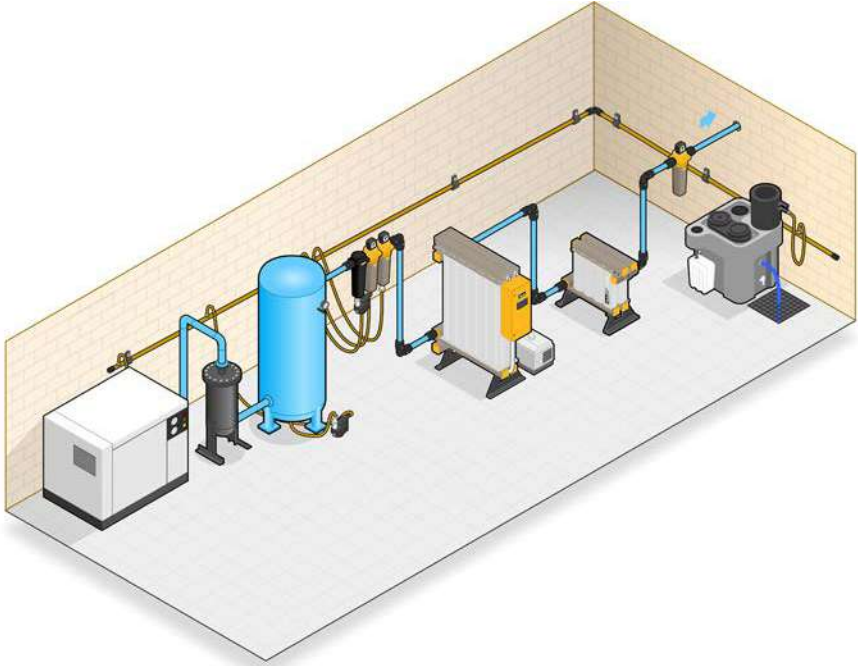

Heatless adsorption dryers (also known as PSA dryers) are the simplest type of adsorption dryer available and have long been the dryer of choice for many industries and applications. They are simple, reliable and cost effective and for small to medium flow systems, often

the only viable technology available. Additionally, modular heatless dryers such as MXLE provide an even more reliable, smaller, more compact & lightweight dryer which can be installed in both the compressor room or at the point of use.

Benefits of Heatless Adsorption Dryers

- Industry proven design
- Suitable for all industries and applications - some adsorption dryer regeneration methods prevent their use in certain industries / applications
- Lower capital investment compared to other adsorption dryer regeneration methods
- Reduced complexity compared to other adsorption dryer regeneration methods
- Robust & reliable
- Uses clean, dry compressed air for regeneration making them suitable for all industries and applications
- Lower maintenance costs compared to other adsorption dryer regeneration methods
- No heat / heaters / heat related issues



RELIABILITY



QUALITY



EFFICIENCY

Improving manufacturing efficiency

Every manufacturing organisation strives to improve its operational efficiency, especially in terms of energy consumption and environmental impact.

Heatless adsorption dryers use clean, dry process air for regeneration, but in real terms, this means that not all of the compressed air generated is available for manufacturing processes.

Generating compressed air uses electrical energy, so although heatless adsorption dryers have many benefits, the energy costs associated with this

type of dryer may be higher when compared to other types of adsorption dryers with different regeneration methods.



MXLE Low Energy Heatless Adsorption Dryers

MXLE has been specifically designed to provide all of the benefits of a traditional MX heatless adsorption dryer with the additional benefits of increased compressed air available for plant use, lower energy costs and lower environmental impact.

Dryer Selection

Dryers should not be selected upon energy costs alone, but on delivered air quality, their suitability for the industry & application in which they are to operate, reliability and total cost of ownership.

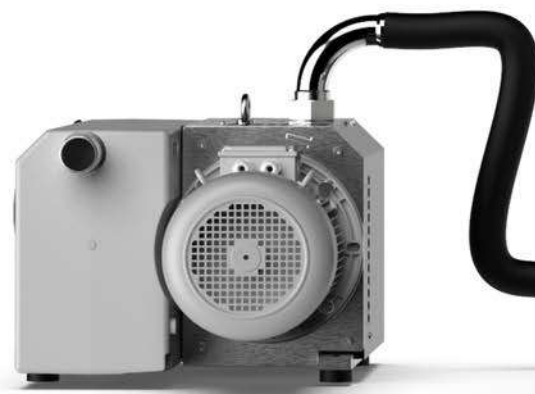

MXLE

Features & Benefits

- **Complete clean dry air solution with guaranteed air quality**
 - Includes Pre & Post Filtration
 - Delivered air quality in accordance with ISO8573-1
 - 3rd Party validated performance on both dryer and pre / post filtration
 - Dryer tested in accordance with ISO7183
 - Filters tested in accordance with ISO12500-1 / ISO8573-4
- **Modular construction**
 - Smaller, more compact & lightweight than traditional Twin Tower dryers
 - Fully expandable as your system grows
 - Existing MX dryers can be upgraded to extend life of existing capital equipment and lower capital expenditure
- **Low energy heatless technology**
 - 17% more air available for use than a comparative heatless dryer
 - On average, 60% lower energy consumption than a comparative heatless dryer & 39% lower energy consumption than a comparative heat regenerative dryer
- **Energy Management System fitted as standard for additional savings**
- **Suitable for all industrial applications**
- **Ideally suited for food, beverage and pharmaceutical industries & applications**
 - Uses clean dry process air for regeneration (no contamination of adsorption bed)
 - Materials of Construction FDA Title 21 Compliant and EC1935-2004 exempt
- **Heatless fall back mode for extra security**
 - Extra security – should a fault occur with the vacuum pump, dryer can be operated in full heatless mode to keep plant operational
- **Lower total cost of ownership**
 - Low running costs
 - Shorter maintenance times & extended preventative maintenance periods
 - Lower maintenance costs compared to other types of low energy dryer

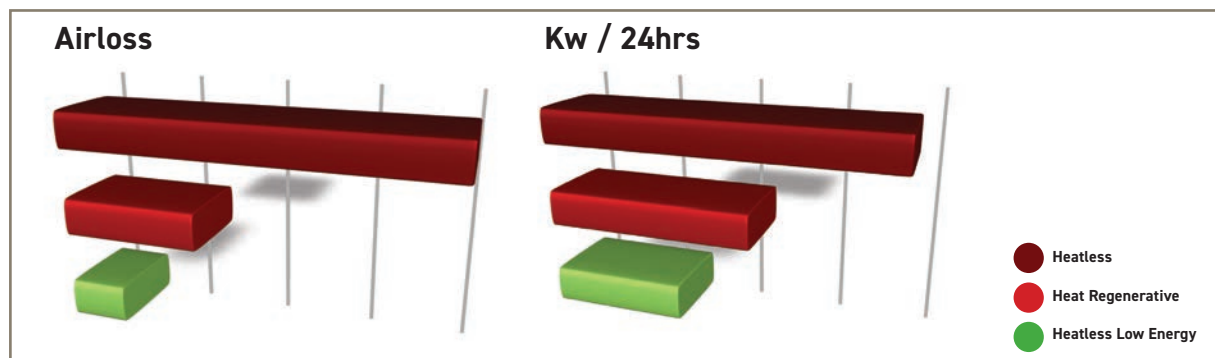

MXLE

Product selection

	Model	Pipe Size	Flowrates			
			L/s	m ³ /min	m ³ /hr	cfm
Single Bank	MXLE 102C	2"	113	6.81	408	240
	MXLE 103C	2"	170	10.22	612	360
	MXLE 103	2"	213	12.78	765	450
	MXLE 104	2½"	283	17.03	1020	600
	MXLE 105	2½"	354	21	1275	750
	MXLE 106	2½"	425	26	1530	900
	MXLE 107	2½"	496	30	1785	1050
	MXLE 108	2½"	567	34	2040	1200



Stated flows are for operation at 7 bar g (100 psi g) with reference to 20 °C, 1 bar a, 0 % relative water vapour pressure.
For flows at other pressures apply the correction factors shown.

Dryer performance

Dryer Models	Dewpoint (Standard)		ISO8573-1:2010 Classification (standard)	Dewpoint (Option 1)		ISO8573-1:2010 Classification (Option 1)	Dewpoint (Option 2)		ISO8573-1:2010 Classification (Option 2)
	°C	°F		°C	°F		°C	°F	
MXLE	-40	-40	Class 2:2:2	-70	-100	Class 2:1:2	-20	-4	Class 2:3:2

* ISO8573-1 Classifications when used with included Parker OIL-X pre / post filtration

Technical data

Dryer Models	Min Operating Pressure		Max Operating Pressure		Min Operating Temp		Max Operating Temp		Max Ambient Temp		Electrical supply (standard)	Electrical supply (optional)	Thread Connections	Noise Level dB (A)
	bar g	psi g	bar g	psi g	°C	°F	°C	°F	°C	°F				
MXLE	5	58	13	190	5	41	50	122	55	131	400V +/- 10% 3PH 50Hz 460V +/- 4.35% 3PH 60Hz	N/A	BSPP	<75

Model		MXLE102c	MXLE103c	MXLE103	MXLE104	MXLE105	MXLE106	MXLE107	MXLE108
Vacuum Pump kW	50Hz	3	3	4	5.5	5.5	7	8.5	9.5
	60Hz	3.6	3.6	4.8	6.6	6.6	8.4	10.2	11.4

Correction factors

Temperature Correction Factor CFT										
Maximum Inlet Temperature	°C	25	30	35	40	45	50			
	°F	77	86	95	104	113	122			
	CFT	1.00	1.00	1.00	1.04	1.14	1.37			
Pressure Correction Factor CFP										
Minimum Inlet Pressure	bar g	5	6	7	8	9	10	11	12	13
	psi g	73	87	100	116	131	145	160	174	189
	CFP	1.33	1.14	1.00	0.89	0.80	0.73	0.67	0.62	0.57
Dewpoint Correction Factor CFD		Option 2	Standard	Option 1						
Required Dewpoint	PDP °C	-20	-40	-70						
	PDP °F	-4	-40	-100						
	CFD	0.91	1.00	1.43						

For correct operation, compressed air dryers must be sized for the minimum inlet pressure, maximum inlet temperature and maximum flow rate at the point of installation.

To select a dryer, first calculate the MDC (Minimum Drying Capacity) using the formula below then select a dryer from the flow rate table above, with a flow rate equal to or greater than the MDC.

$$\text{Minimum Drying Capacity} = \text{System Flow} \times \text{CFT} \times \text{CFP} \times \text{CFD}$$

Dryer coding example

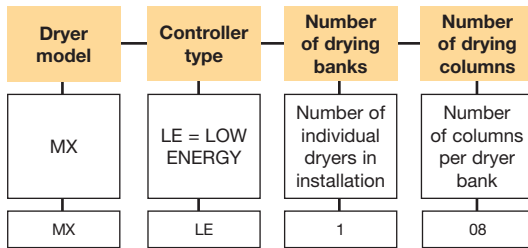

Part numbers

Dryer Part Numbers		Vacuum Pump Part Numbers 50Hz / 60Hz	Dryer Upgrade Kits Part Numbers
-20°C / -40°C PDP	-70°C PDP		
MXLE102C	MXLE102C-70	HLVAP-OL-01-100	MXLEK2C
MXLE103C	MXLE103C-70	HLVAP-OL-01-110	MXLEK3C
MXLE103	MXLE103-70	HLVAP-OL-01-120	MXLEK3
MXLE104	MXLE104-70	HLVAP-OL-01-130	MXLEK4
MXLE105	MXLE105-70	HLVAP-OL-01-140	MXLEK5
MXLE106	MXLE106-70	HLVAP-OL-01-150	MXLEK6
MXLE107	MXLE107-70	HLVAP-OL-01-160	MXLEK7
MXLE108	MXLE108-70	HLVAP-OL-01-170	MXLEK8

Weights and dimensions

Model	Pipe Size	Dryer Dimensions							
		Height (H)		Width (W)		Depth (D)		Weight	
		mm	ins	mm	ins	mm	ins	kg	lbs
MXLE 102C	2"	1647	64.8	793.5	31.5	550	21.7	265	583
MXLE 103C	2"	1647	64.8	962.5	37.9	550	21.7	346	761
MXLE103	2"	1892	74.5	962.5	37.9	550	21.7	385	847
MXLE104	2½"	1892	74.5	1131.5	44.6	550	21.7	480	1056
MXLE105	2½"	1892	74.5	1300.5	51.2	550	21.7	573	1261
MXLE106	2½"	1892	74.5	1469.5	57.9	550	21.7	667	1467
MXLE107	2½"	1892	74.5	1641.5	64.6	550	21.7	761	1674
MXLE108	2½"	1892	74.5	1807.5	71.2	550	21.7	855	1881

Model	Vacuum Pump Dimensions							
	Height (H)		Width (W)		Depth (D)		Weight	
	mm	ins	mm	ins	mm	ins	kg	lbs
HLVAP-OL-01-100	354	13.9	835	32.9	510	20.1	119	262
HLVAP-OL-01-110	354	13.9	835	32.9	510	20.1	119	262
HLVAP-OL-01-120	354	13.9	854	33.6	510	20.1	128	282
HLVAP-OL-01-130	354	13.9	946	37.2	510	20.1	171	377
HLVAP-OL-01-140	354	13.9	946	37.2	510	20.1	171	377
HLVAP-OL-01-150	1320	52.0	980	38.6	650	25.6	287	633
HLVAP-OL-01-160	1320	52.0	1070	42.1	650	25.6	330	728
HLVAP-OL-01-170	1320	52.0	1070	42.1	650	25.6	339	747

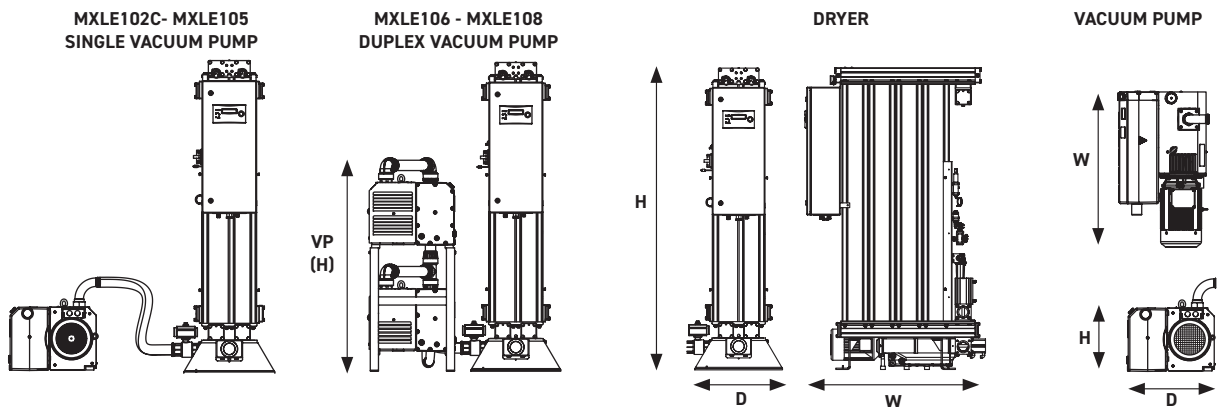

Included filtration

For Dryer Model	Filter Pipe Size BSPP	Inlet General Purpose Pre-filter	Inlet High Efficiency Filter	Outlet Dry Particulate Filter
MXLE 102C	2"	AOPX040H	AAPX040H	AOPX040H
MXLE 103C	2"	AOPX040H	AAPX040H	AOPX040H
MXLE 103	2"	AOPX040H	AAPX040H	AOPX040H
MXLE 104	2½"	AOPX045I	AAPX045I	AOPX045I
MXLE 105	2½"	AOPX050I	AAPX050I	AOPX050I
MXLE 106	2½"	AOPX050I	AAPX050I	AOPX050I
MXLE 107	2½"	AOPX055I	AAPX055I	AOPX055I
MXLE 108	2½"	AOPX055I	AAPX055I	AOPX055I

Parker Worldwide

Europe, Middle East, Africa

AE – United Arab Emirates,

Dubai

Tel: +971 4 8127100

AT – Austria, St. Florian

Tel: +43 (0)7224 66201

AZ – Azerbaijan, Baku

Tel: +994 50 2233 458

BE/NL/LU – Benelux,

Hendrik Ido Ambacht

Tel: +31 (0)541 585 000

BY – Belarus, Minsk

Tel: +48 (0)22 573 24 00

CH – Switzerland, Etoy

Tel: +41 (0)21 821 87 00

CZ – Czech Republic,

Prague

Tel: +420 284 083 111

DE – Germany, Kaarst

Tel: +49 (0)2131 4016 0

DK – Denmark, Ballerup

Tel: +45 43 56 04 00

ES – Spain, Madrid

Tel: +34 902 330 001

FI – Finland, Vantaa

Tel: +358 (0)20 753 2500

FR – France, Contamine s/Arve

Tel: +33 (0)4 50 25 80 25

GR – Greece

Tel: +30 69 44 52 78 25

HU – Hungary, Budaörs

Tel: +36 23 885 470

IE – Ireland, Dublin

Tel: +353 (0)1 466 6370

IL – Israel

Tel: +39 02 45 19 21

IT – Italy, Corsico (MI)

Tel: +39 02 45 19 21

KZ – Kazakhstan, Almaty

Tel: +7 7273 561 000

NO – Norway, Asker

Tel: +47 66 75 34 00

PL – Poland, Warsaw

Tel: +48 (0)22 573 24 00

PT – Portugal

Tel: +351 22 999 7360

RO – Romania, Bucharest

Tel: +40 21 252 1382

RU – Russia, Moscow

Tel: +7 495 645-2156

SE – Sweden, Borås

Tel: +46 (0)8 59 79 50 00

SL – Slovenia, Novo Mesto

Tel: +386 7 337 6650

TR – Turkey, Istanbul

Tel: +90 216 4997081

UK – United Kingdom, Warwick

Tel: +44 (0)1926 317 878

ZA – South Africa, Kempton Park

Tel: +27 (0)11 961 0700

North America

CA – Canada, Milton, Ontario

Tel: +1 905 693 3000

US – USA, Cleveland

Tel: +1 216 896 3000

Asia Pacific

AU – Australia, Castle Hill

Tel: +61 (0)2-9634 7777

CN – China, Shanghai

Tel: +86 21 2899 5000

HK – Hong Kong

Tel: +852 2428 8008

IN – India, Mumbai

Tel: +91 22 6513 7081-85

JP – Japan, Tokyo

Tel: +81 (0)3 6408 3901

KR – South Korea, Seoul

Tel: +82 2 559 0400

MY – Malaysia, Shah Alam

Tel: +60 3 7849 0800

NZ – New Zealand, Mt Wellington

Tel: +64 9 574 1744

SG – Singapore

Tel: +65 6887 6300

TH – Thailand, Bangkok

Tel: +662 186 7000

TW – Taiwan, Taipei

Tel: +886 2 2298 8987

South America

AR – Argentina, Buenos Aires

Tel: +54 3327 44 4129

BR – Brazil, Sao Jose dos Campos

Tel: +55 080 0727 5374

CL – Chile, Santiago

Tel: +56 22 303 9640

MX – Mexico, Toluca

Tel: +52 72 2275 4200



EMEA Product Information Centre

Free phone: 00 800 27 27 5374

(from AT, BE, CH, CZ, DE, DK, EE, ES, FI, FR, IE, IL, IS, IT, LU, MT, NL, NO, PL, PT, RU, SE, SK, UK, ZA)

US Product Information Centre

Toll-free number: 1-800-27 27 537

www.parker.com/gsf